



MAXFire® HC Gas Igniters

Replace existing oil igniters with Forney's high capacity gas igniters to reduce operating costs associated with coal firing.

Product Overview

The MAXFire® HC (High Capacity) gas igniter is a Class 1 igniter designed to allow the boiler to operate on coal or gas. The MAXFire® igniter is easily installed as a retrofit into a 6" or greater mount tube.

MAXFire® HC gas igniters consist of six major components: main tip, pilot igniter, HESI Spark Rod, Flame Rod, HESI Power Pack, and Flame Rod Module. Separate flame detector option available in lieu of flame rod for superior flame detection.

The main igniter tip is arranged to surround the flame of the pilot igniter for ease of ignition and stable operation. The main igniter shares a gas fuel supply with the pilot igniter through a pressure regulator, therefore, the pilot igniter is on whenever the main igniter is on and that ensures stable operation of the main igniter.

The pilot igniter consists of a guide tube, a gas transport tube, a spark rod, and a stainless steel diffuser for pilot stabilization. The guide tube houses the spark rod and the gas transport tube, which are easily removed from the guide tube for maintenance purposes by releasing a "V" band retainer, requiring no tools. Cooling/combustion airflow is directed down the guide tube to support and maintain the primary combustion zone during operation. The controlled mixture of fuel and air in the primary combustion zone results in a highly reliable, stable igniter flame. While out of service, airflow cools the igniter and prevents debris from migrating into the end of the guide tube.

MAXFire® HC gas igniters come standard with Forney's High Energy Spark Igniter (HESI) as the spark source. The HESI produces a powerful 12-joule spark approximately three times per second at the primary combustion zone. The HESI spark tip is a nonfouling, surface-gap tip which is replaceable as a unit by a threaded connection.

Features & Benefits

- **CLASS 1 GAS IGNITER**
Capacity range from 30 to 50 MBtu/hr (8.79 to 14.65 MW).
- **APPLICATION FLEXIBILITY**
Protected primary combustion zone ensures reliable operation in multiple environments.
 - 50 to 15 MBtu/Hr Turndown
 - Continuous Duty Igniter
- **RELIABLE IGNITION**
99% ignition rate in most applications. The non-fouling HESI comes standard.
- **COOLING / COMBUSTION AIR**
Low cooling/combustion air requirements.
- **LOW MAINTENANCE REQUIREMENTS**
No moving parts, a self-cleaning spark tip and no tools required to perform periodic inspection.
- **DURABILITY**
Heavy duty material and no moving parts to wear out.
- **COMPATIBILITY**
Fits 6" and above mount tubes minimizing retrofit installation costs.

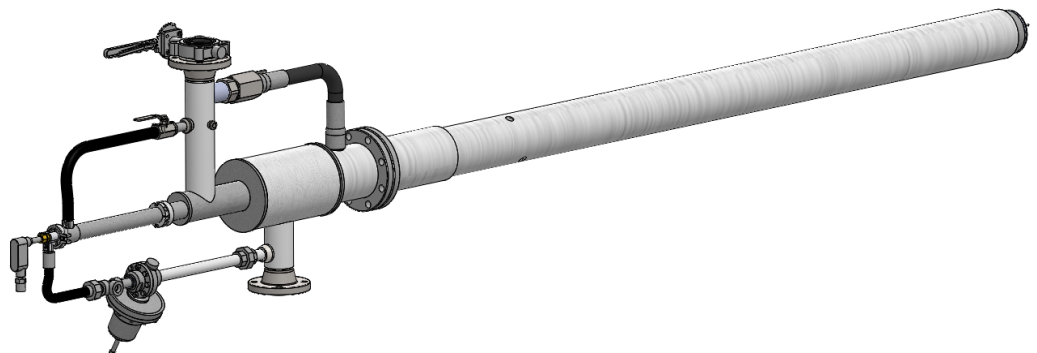

MAXFire® HC Gas Igniters

Igniter Specifications

Igniter Class:	Class 1
Fuel:	Natural gas
Length:	30 inches (762 mm) - 110 inches (2794 mm) as needed by application
Guide Tube Material:	Carbon steel with stainless steel at furnace end
Capacity:	30 to 50 MBtu/hr (8.79 to 14.65MW)
Guide Tube OD:	Minimum 6" and above
Air Requirement:	min 200 @ min 6 scfm@inches w.c. above furnace
Nozzle Type:	Wide Angle
Typical Fuel Pressure:	5-25 psig (0.35 - 1.76 kg/cm ²)

HESI Specifications

Material:	Carbon Steel
Input Voltage:	120 to 240 VAC, 50/60 Hz
Input Power:	120 VAC @ 1.5 A (2-A fuse); 240 VAC @ 0.75A (1-A fuse)
Output Voltage:	2000 VDC
Output Energy:	12 joules per spark
Spark Rate:	3 per second (approximately)
Duty Cycle:	50% at temp 0°F to 135°F (-18°C to 57°C) Ambient

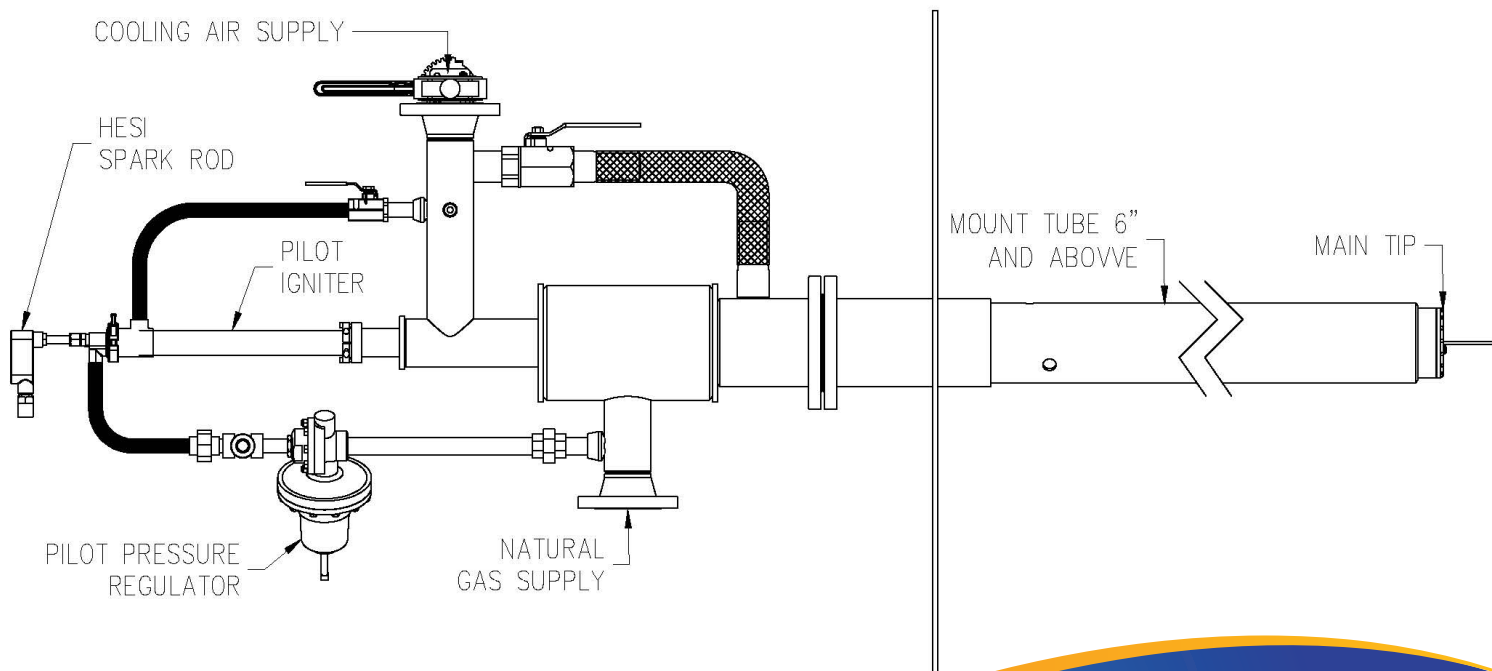

Forney Corporation

16479 N. Dallas Parkway, Suite 600 • Addison, TX 75001
800-356-7740 • Fax 972-458-6650 • www.forneycorp.com